

STRAIN-SPACE PLASTICITY FORMULATION FOR HARDENING-SOFTENING MATERIALS WITH ELASTOPLASTIC COUPLING

D. J. HAN and W. F. CHEN
School of Civil Engineering, Purdue University, West Lafayette, IN 47907, U.S.A.

(Received 26 October 1984; in revised form 29 April 1985)

Abstract—Engineering materials such as concretes, rocks and soils exhibit a strong strain-softening behavior in the post-failure range, showing a significant elastoplastic coupling for the degradation of elastic modulus with increasing plastic deformation. Stress-space formulation of plasticity based on Drucker's stability postulate for these materials encounters difficulties in modeling the softening/elastoplastic coupling behavior; strain-space formulation is therefore necessary for further progress. In this article we first introduce a general form of strain-space plasticity formulation which is somewhat similar to that developed previously by Yoder and Iwan. To account for the elastoplastic coupling effect, the conventional plasticity theory is combined with the fracturing theory of Dougill to give a more general form of strain-space formulation. Attempt is then made to apply the general theory to model the softening behavior of a concrete element failed in a mixed crushing/cracking mode.

1. INTRODUCTION

Many engineering materials such as concretes, rocks and soils exhibit a significant strain-softening behavior beyond the peak or failure stress. Figure 1 shows a typical concrete uniaxial compressive stress-strain curves obtained from a strain-controlled test. Each of these curves has a sharp descending branch beyond the peak or failure stress. Consider the descending branch or the softening behavior of a typical stress-strain curve shown in Fig. 2. As the strain increases, the stress must decrease, otherwise the materials would accelerate

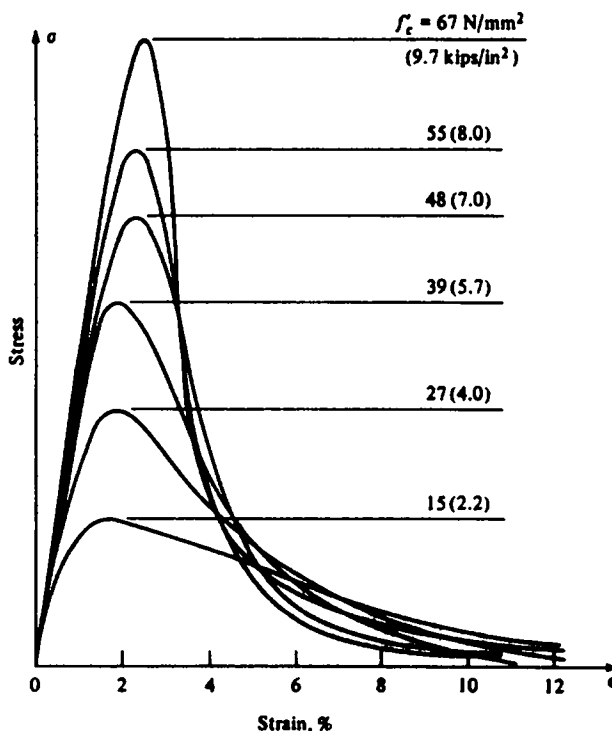

Fig. 1. Complete compressive stress-strain curve.

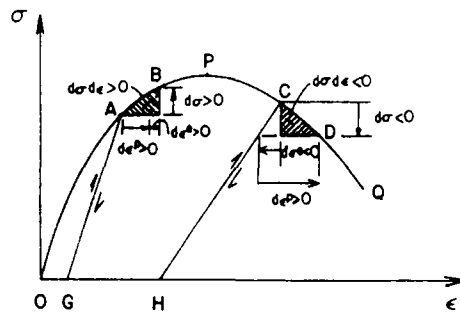

Fig. 2. Features of softening behavior.

to failure. However, if the strain is decreased instead of increased at point C, the stress must still decrease but now along an elastic unloading line CH. Reloading would trace back the unloading line until the yield stress at point C is reached. In the classical theory of plasticity, the elastic properties are assumed to be independent of the plastic deformation, i.e. the unloading-reloading line will follow the straight line that is parallel to the initial tangent of the stress-strain curve. However, this is not true for granular type of materials like concretes, rocks and soils, whose unloading-reloading behavior is much more complicated. Figure 3 (Sinha *et al.*[1]) shows a typical uniaxial compressive stress-strain curve of concrete under cyclic loading. As can be seen, the unloading-reloading curves are not straight line segments but loops of changing size and decreasing average slope. An approximation of this average slope is the slope of a line connecting the turning points of one cycle (Dafalias[2]). Thus we may assume that the material behavior upon unloading and re-loading is of linearly elastic (dotted lines in Fig. 3), but the elastic modulus (or the slope) degrades with the increase of plastic deformation. This is called elastoplastic coupling which becomes much more significant in the softening branch of a stress-strain curve. For rocks and concretes, softening and loss of stiffness are caused by progressive fracture.

The one-dimensional softening behavior is now generalized to a multiaxial state of stress and strain in a similar manner to that of hardening behavior. We first discuss the softening behavior in stress space. This will then be extended and lead to a discussion in strain-space formulation. In a stress-space formulation, a state of stress is represented by a point in stress space [Fig. 4(a)]. If the state "A" is on the loading surface $f = 0$, but the material is still in the range of work-hardening, a stress increment $d\sigma$ must point outward in order to produce a plastic as well as elastic increment of strain. A stress increment pointing inward would cause elastic strain only. The outward motion of the stress point "A" carrying with it the yield surface corresponds to a hardening or ascending branch of the stress-strain curve for an increasing stress in the one-dimensional. On the other hand, if the material is in the range of strain-softening, plastic deformation causes the yield surface to contract or move inward at the current stress point "C" [Fig. 4(a)]. This inward motion

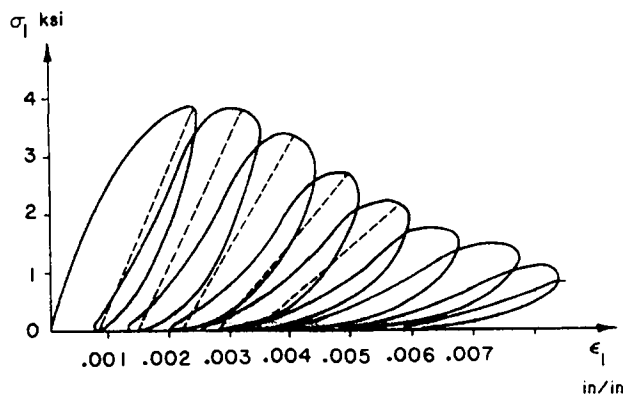

Fig. 3. Cyclic uniaxial compressive stress-strain curve.

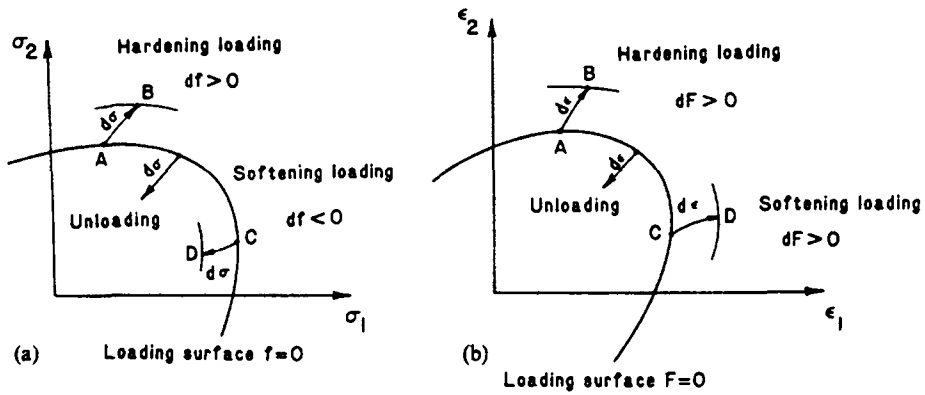

Fig. 4. Loading surfaces defined in (a) stress- and (b) strain-space.

corresponds to a softening or descending branch of the stress-strain curve for increasing strain in the one-dimensional case. For elastic unloading, too, the stress increment $d\sigma$ points inward of the loading surface. Hence the stress-space formulation presents difficulty in distinguishing between a reduction of stress which causes additional plastic deformation and one due to elastic unloading. Referring to points *A* and *C* in Fig. 2, however, the strain increment $d\epsilon$ is always positive for a plastic loading and negative for an elastic unloading along either path *AG* or path *CH*. A generalization to the multidimensional case is shown in Fig. 4(b), where the loading surface, $F = 0$, is a function of strains. For any strain point (*A* or *C*, for example) on the loading surface, the strain increment $d\epsilon$ points outward, representing a plastic loading case, and inward, representing an elastic unloading case. There is no ambiguity. It seems clear that if strain is used as an independent variable in formulating the plasticity constitutive relation, hardening and softening behavior may be studied simultaneously. In fact, the advantages of strain-space plasticity have been recognized by many researchers[2-5]. Specifically, a strain-space formulation has been given by Yoder and Iwan[5] and by Casey and Naghdi[6]. It has been shown that many of the familiar features of stress-space plasticity can be carried over to strain-space, although the stress-space and strain-space formulations are not equivalent.

The impetus of this investigation is to model the softening behavior with elastoplastic coupling effect. In this paper, we first introduce in Section 2 a general form of strain-space formulation of plasticity which is somewhat similar to that developed previously by Yoder and Iwan[5]. But there is no elastoplastic coupling considered in Yoder and Iwan's formulation. The fracturing theory discussed in Section 3 was proposed by Dougill[7, 8]. This theory attributes the stiffness degradation of a granular type of material to the fracturing process. To combine the plastic and fracturing theories, a more general strain-space formulation, including elastoplastic coupling, is developed in Section 4. The consideration of combining plastic and fracturing behavior is originally inspired by the plastic-fracturing theory of Bazant and Kim[9], but the formulation presented here is entirely different. Since the plastic-fracturing theory, formulated in stress- and strain-space simultaneously encountered difficulties in defining a loading criterion, in Section 4, formulation is given in strain-space only. The combined theory accounts for the plastic deformation and elastoplastic coupling, and can generally be applied to the entire range of loadings including strain hardening and softening.

Attempt is also made here to apply the theory to model the softening behavior of concrete material. This is described in Section 5 where a constitutive relation for concrete is established. More details of the constitutive modeling of concrete may be found in Refs. [10-12].

2. PLASTICITY FORMULATION IN STRAIN-SPACE

In order to formulate the theory in a relatively general form, the concept of external variable and plastic internal variables[13] will be employed here to describe the state of a

material point. In this development, we will consider only the rate-independent behavior for an isothermal process, so that time and temperature will not appear in the formulation.

The loading surfaces (initial and subsequent yield surfaces) in strain space can be generally expressed as

$$F(\epsilon_{ij}, q_n) = 0, \tag{1}$$

where ϵ_{ij} is strain tensor. Since strains can be measured or observed, they are considered as external variables. q_n are the plastic internal variables or (PIVs). For elastic-plastic materials, plastic strains ϵ_{ij}^p , and plastic work W^p are the most common PIVs. In addition, if we consider a kinematic translation of the loading surface during a plastic loading, the coordinates of the center of a loading surface α_{ij} are also PIVs. Thus eqn (1) can be expressed more definitely as

$$F[(\epsilon_{ij} - \alpha_{ij}), \epsilon_{ij}^p, W^p] = 0. \tag{2}$$

Another PIV, σ_{ij}^p , introduced in [5] as relaxation stress σ^R , is related to ϵ_{ij}^p by the equation

$$\sigma_{ij}^p = C_{ijkl} \epsilon_{kl}^p, \tag{3}$$

where C_{ijkl} is the isotropic tensor of elastic moduli. It has the form in the usual notation

$$C_{ijkl} = \frac{\nu E}{(1 + \nu)(1 - 2\nu)} \delta_{ij} \delta_{kl} + \frac{E}{2(1 + \nu)} (\delta_{ik} \delta_{jl} + \delta_{il} \delta_{jk}), \tag{4}$$

and σ_{ij}^p can also be considered as the residual stress with the sign reversed [see Fig. 5(a)].

Denote σ_{ij}^e as the elastic response of total strain ϵ_{ij} such that

$$\sigma_{ij}^e = C_{ijkl} \epsilon_{kl}. \tag{5}$$

Thus the total stress σ_{ij} is the difference between σ_{ij}^e and σ_{ij}^p , i.e.

$$\sigma_{ij} = \sigma_{ij}^e - \sigma_{ij}^p. \tag{6}$$

On the other hand, the total strain ϵ_{ij} is the sum of elastic and plastic strain

$$\epsilon_{ij} = \epsilon_{ij}^e + \epsilon_{ij}^p, \tag{7}$$

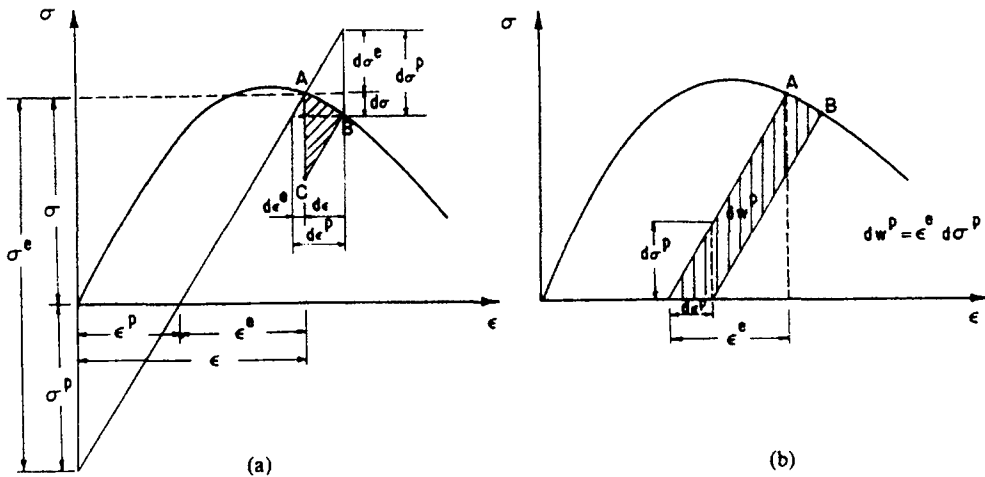

Fig. 5. Schematic description of plasticity formulation based on Il'yushin's postulate: (a) stress and strain increments; (b) plastic work increment.

in which ε_{ij}^e is the elastic response to the total stress σ_{ij} , i.e.

$$\varepsilon_{ij}^e = D_{ijkl}\sigma_{kl}, \quad (8)$$

where the elastic compliance tensor D_{ijkl} is the inverse of C_{ijkl} , and has the form

$$D_{ijkl} = -\frac{\nu}{E}\delta_{ij}\delta_{kl} + \frac{1+\nu}{2E}(\delta_{ik}\delta_{jl} + \delta_{il}\delta_{jk}). \quad (9)$$

The relations of these quantities are shown schematically in Fig. 5(a) for the one-dimensional case and summarized in the following two equations:

$$\sigma_{ij} = \sigma_{ij}^e - \sigma_{ij}^p = C_{ijkl}\varepsilon_{kl} - \sigma_{ij}^p, \quad (10)$$

$$\varepsilon_{ij} = \varepsilon_{ij}^e + \varepsilon_{ij}^p = D_{ijkl}\sigma_{kl} + \varepsilon_{ij}^p. \quad (11)$$

Il'yushin's postulate[14] states that the work done by the external forces in a closed-cycle of deformation of an elastoplastic material is nonnegative, i.e. the work is positive if plastic deformation takes place, and is zero if only elastic deformation occurs. The shaded area in Fig. 5(a), dW , represents the work done in a deformation cycle $A-B-C$. According to Il'yushin's postulate, we have

$$dW = \frac{1}{2} d\sigma_{ij}^p d\varepsilon_{ij} \geq 0, \quad (12)$$

from which the normality rule or flow rule follows

$$d\sigma_{ij}^p = d\lambda \frac{\partial F}{\partial \varepsilon_{ij}}. \quad (13)$$

The normality rule for an unstable material has been discussed by Palmer *et al.*[15]. Equation (13) is known as the associated flow rule. More generally, consider a nonassociated flow rule by assuming a plastic potential function G in strain-space such that

$$G = G(\varepsilon_{ij}, q_n) = 0. \quad (14)$$

Thus

$$d\sigma_{ij}^p = d\lambda \frac{\partial G}{\partial \varepsilon_{ij}}. \quad (15)$$

In eqns (13) and (15), $d\lambda$ is a scalar determined by the consistency condition of the loading surface (2) as

$$dF = \frac{\partial F}{\partial \varepsilon_{ij}} d\varepsilon_{ij} - \frac{\partial F}{\partial \alpha_{ij}} d\alpha_{ij} + \frac{\partial F}{\partial \varepsilon_{ij}^p} d\varepsilon_{ij}^p + \frac{\partial F}{\partial W^p} dW^p = 0. \quad (16)$$

Inverting the incremental form of eqn (3) and recalling eqn (15),

$$d\varepsilon_{ij}^p = [C_{ijkl}]^{-1} d\sigma_{kl}^p = d\lambda D_{ijkl} \frac{\partial G}{\partial \varepsilon_{kl}}. \quad (17)$$

By definition, the increment of the plastic work dW^p is expressed as [see Fig. 5(b)]

$$dW^p = \varepsilon_{ij}^e d\sigma_{ij}^p = d\lambda \varepsilon_{kl}^e \frac{\partial G}{\partial \varepsilon_{kl}}. \quad (18)$$

The rate of translation of the loading surface, $d\alpha_{ij}$, depends on a kinematic hardening rule. If Ziegler's rule is adopted, then

$$\begin{aligned} d\alpha_{ij} &= c\sqrt{d\sigma_{kl}^p d\sigma_{kl}^p}(\epsilon_{ij} - \alpha_{ij}) \\ &= c d\lambda \sqrt{\frac{\partial G}{\partial \epsilon_{kl}} \frac{\partial G}{\partial \epsilon_{kl}}}(\epsilon_{ij} - \alpha_{ij}), \end{aligned} \tag{19}$$

in which c is a dimensional constant.

Substituting eqns (17) through (19) into eqn (16) and solving for $d\lambda$, we have

$$d\lambda = \frac{1}{h} \frac{\partial F}{\partial \epsilon_{ij}} d\epsilon_{ij}, \tag{20}$$

where

$$h = -\left[\frac{\partial F}{\partial \epsilon_{mn}^p} D_{mnpq} \frac{\partial G}{\partial \epsilon_{pq}} + \frac{\partial F}{\partial W^p} \epsilon_{kl}^p \frac{\partial G}{\partial \epsilon_{kl}} - c \frac{\partial F}{\partial \epsilon_{rs}} (\epsilon_{rs} - \alpha_{rs}) \sqrt{\frac{\partial G}{\partial \epsilon_{ij}} \frac{\partial G}{\partial \epsilon_{ij}}} \right].$$

Substitution of eqn (20) into eqn (15) yields

$$d\sigma_{ij}^p = \frac{1}{h} \frac{\partial G}{\partial \epsilon_{ij}} \frac{\partial F}{\partial \epsilon_{kl}} d\epsilon_{kl}. \tag{21}$$

By using the incremental form of eqn (10) and substituting eqn (21) into eqn (10), the general constitutive equation for the stress increment $d\sigma_{ij}$ is obtained as

$$d\sigma_{ij} = \left[C_{ijkl} - \frac{1}{h} \frac{\partial G}{\partial \epsilon_{ij}} \frac{\partial F}{\partial \epsilon_{kl}} \right] d\epsilon_{kl}. \tag{22}$$

The constitutive equations given by (20)–(22) are valid for the whole loading range, including work-hardening and softening. In this formulation, the loading function F and the plastic potential function G are expressed in strain-space and the material history is represented by the plastic internal variables (PIVs) ϵ_{ij}^p , W^p and α_{ij} .

3. PROGRESSIVE FRACTURING MODEL

An ideal material model, the so-called progressively fracturing solid, was proposed by Dougill[7, 8]. This theory emphasizes on the modeling of stiffness degradation that occurs during the progressive fracturing in a solid. Here, as in plasticity, Dougill begins by introducing a fracturing surface in strain space as

$$F(\epsilon_{ij}, H_k) = F(\epsilon_{ij}) - H(W^I) = 0. \tag{23}$$

which is assumed to enclose all the strain points that can be attained without further fracturing. During the progressive fracture, the fracture surface expands in order to accommodate the additional strain states that can be reached by the linear elastic behavior alone. Dougill proceeds to assume that the fractured material is perfectly elastic. Therefore, upon unloading, the material returns to its initial stress and strain-free state, and the original dimensions are fully recovered [Fig. 6(a)]. Thus stress is related to strain at all times by Hooke's law,

$$\sigma_{ij} = C_{ijkl} \epsilon_{kl}, \tag{24}$$

but the tensor of elastic moduli C_{ijkl} in eqn (24) will change due to a progressively fracturing

loading process such that

$$d\sigma_{ij} = C_{ijkl} d\epsilon_{kl} + dC_{ijkl} \epsilon_{kl}. \tag{25}$$

Hence the stress increment $d\sigma_{ij}^e$ is the same as that of an elastic component

$$d\sigma_{ij}^e = C_{ijkl} d\epsilon_{kl}, \tag{26}$$

and the fracture stress decrement, denoted by $-d\sigma_{ij}^f$, has the form

$$-d\sigma_{ij}^f = dC_{ijkl} \epsilon_{kl}. \tag{27}$$

On the other hand, the Il'yushin's postulate requires that the work done upon applying and removing $d\epsilon_{ij}$ be nonnegative, i.e.

$$\Delta W = \frac{1}{2} d\sigma_{ij}^f d\epsilon_{ij} \geq 0. \tag{28}$$

The ΔW is shown as the shaded area in Fig. 6(a). Note that in the figure the difference between AC and DB ($d\sigma^f$) is of a higher-order infinitesimal, and can therefore be neglected in the work calculation. Following the similar arguments to that used in the development of the theory of plasticity, we obtain the flow rule, for a progressively fracturing solid,

$$d\sigma_{ij}^f = d\lambda \frac{\partial F}{\partial \epsilon_{ij}}. \tag{29}$$

The consistency condition of the loading surface is then used to determine the scalar function $d\lambda$,

$$dF = \frac{\partial F}{\partial \epsilon_{ij}} d\epsilon_{ij} - \frac{dH}{dW^f} dW^f = 0, \tag{30}$$

where dW^f is the shaded area indicated in Fig. 6(b). It has the value $dW^f = \frac{1}{2} d\sigma_{ij}^f \epsilon_{ij}$. Substituting eqn (29) into the expression for dW^f and using this results in solving eqn (30) for $d\lambda$, lead to

$$d\lambda = 2 \frac{dW^f}{dH} \frac{(\partial F / \partial \epsilon_{kl}) d\epsilon_{kl}}{(\partial F / \partial \epsilon_{mn}) \epsilon_{mn}}, \tag{31}$$

and thus, we have

$$d\sigma_{ij}^f = 2 \frac{dW^f}{dH} \frac{(\partial F / \partial \epsilon_{ij}) (\partial F / \partial \epsilon_{kl})}{(\partial F / \partial \epsilon_{mn}) \epsilon_{mn}} d\epsilon_{kl}. \tag{32}$$

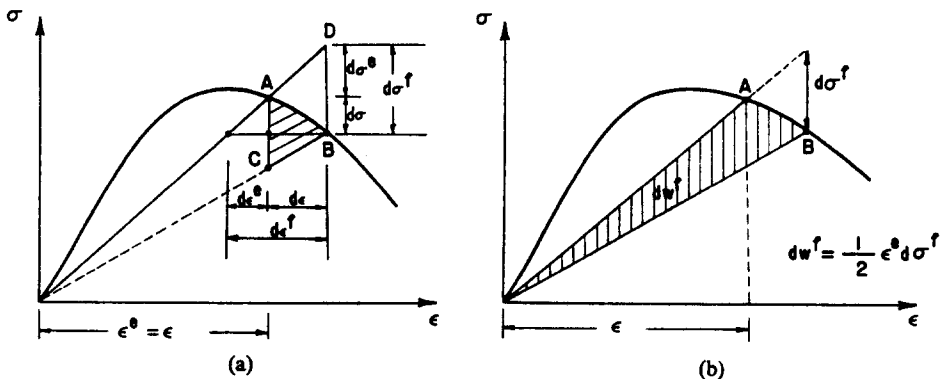

Fig. 6. Progressive fracturing theory [7, 8]: (a) stress and strain increments; (b) fracturing work.

Recalling that $d\sigma_{ij} = d\sigma_{ij}^e + (-d\sigma_{ij}^f)$, and using eqn (26) yields

$$d\sigma_{ij} = \left[C_{ijkl} - 2 \frac{dW^f}{dH} \frac{(\partial F / \partial \epsilon_{ij})(\partial F / \partial \epsilon_{kl})}{(\partial F / \partial \epsilon_{mn})\epsilon_{mn}} \right] d\epsilon_{kl}. \tag{33}$$

This is the general constitutive equation for a progressively fracturing solid.

In order to determine the stiffness degradation rate dC_{ijkl} in eqn (27), Dougill further proposes that the change in stiffness caused by an increment of deformation $d\epsilon_{ij}$ is independent of the deformation path. By using this postulate, as well as eqns (27) and (32), an expression for dC_{ijkl} was obtained.

Dougill’s fracturing material model assumes that no plastic deformation occurred during loading, and that the nonlinearity is purely induced by the stiffness degradation of the material. However, this theory is fundamentally different from the nonlinear elasticity theory. In Dougill’s theory, he assumes the existence of a fracturing surface in strain-space and determines the so-called fracture stress decrement $d\sigma_{ij}^f$ by the normality (or flow) rule. On this account, the stiffness degradation dC_{ijkl} is not a given material property but rather a consequence of the “fracturing flow rule”, i.e. dC_{ijkl} is attributed to a fracturing process. Thus the fracturing theory is similar to the basic concept of classical plasticity theory and therefore belongs to the realm of plasticity.

4. PLASTIC-FRACTURING FORMULATION IN STRAIN-SPACE

As mentioned above, the progressively fracturing theory assumes that the material nonlinearity, either hardening or softening is due solely to the degradation of the fractured material stiffness. In contrast, the classical theory of plasticity assumes that the nonlinearity is due solely to the irreversible deformation induced by slip and that the elastic properties remain unchanged during loading.

For rock-like materials such as concrete, the situation is much more complicated. Both fracturing and slip in the aggregate–cement interface exist, resulting in an irrecoverable deformation and a stiffness degradation. To model the behavior of this type of materials, the plastic-fracturing theory, combining the classical theory of plasticity with the fracturing theory, was proposed by Bazant and Kim[9]. In this theory, the stress increment $d\sigma_{ij}$ was assumed to comprise three components [Fig. 7(a)] as

$$d\sigma_{ij} = d\sigma_{ij}^e - d\sigma_{ij}^p - d\sigma_{ij}^f, \tag{34}$$

where $d\sigma_{ij}^e$ is the elastic response to the total strain increment, i.e.

$$d\sigma_{ij}^e = C_{ijkl} d\epsilon_{kl}, \tag{35}$$

in which $d\sigma_{ij}^p$ is the stress increment related to the plastic strain increment as

$$d\sigma_{ij}^p = C_{ijkl} d\epsilon_{kl}^p, \tag{36}$$

while $d\sigma_{ij}^f$ is the stress increment due to stiffness degradation [see eqn (45)], and is related to the fracturing strain increment as

$$d\sigma_{ij}^f = C_{ijkl} d\epsilon_{kl}^f. \tag{37}$$

In eqns (35)–(37), C_{ijkl} is the tensor of current elastic moduli.

We may define the elastic strain increment $d\epsilon_{ij}^e$ as the elastic response to the total stress increment, i.e.

$$d\epsilon_{ij}^e = D_{ijkl} d\sigma_{kl}, \tag{38}$$

where D_{ijkl} is the tensor of current compliance, the inverse of tensor C_{ijkl} .

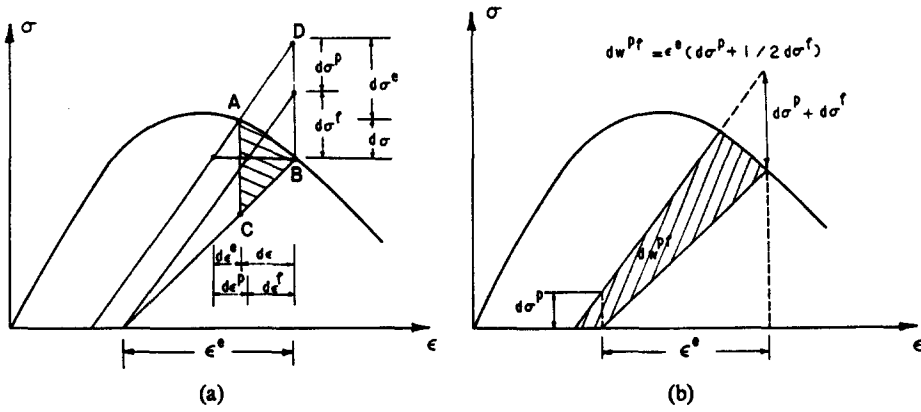

Fig. 7. Schematic description of the combined formulation: (a) stress and strain increments; (b) plastic-fracturing work.

From eqns (34)–(38), a relation for the strain increments $d\epsilon_{ij}$, $d\epsilon_{ij}^e$, $d\epsilon_{ij}^p$, $d\epsilon_{ij}^f$, can be obtained as

$$d\epsilon_{ij} = d\epsilon_{ij}^e + d\epsilon_{ij}^p + d\epsilon_{ij}^f. \tag{39}$$

In contrast, it should be noted here that the total strain ϵ_{ij} comprises only two parts, ϵ_{ij}^e and ϵ_{ij}^p and eqn (7) holds. ϵ_{ij}^p is the plastic (permanent) strain, while ϵ_{ij}^e is the recoverable strain or elastic strain. All these quantities of stresses and strains in one-dimensional case are illustrated in Fig. 7(a).

According to the plastic-fracturing theory by Bazant and Kim, the incremental stress components $d\sigma_{ij}^p$, and $d\sigma_{ij}^f$ are determined by flow rules based on Drucker's postulate and Il'yushin's postulate, respectively. Their theory defines a loading surface in stress-space, and a loading surface in strain-space, independent of each other. Thus their theory is flexible and allows much room to fit the experimental data. However, the loading criterion is quite complicated and somewhat confusing, because during softening, no unique criterion can be defined in stress- and strain-space simultaneously. Nevertheless, the idea of combining these two theories is advisable, and therefore adopted here, but the formulation in what follows will be quite different.

Herein, we assume a loading surface in strain-space, with a form similar to that of eqn (2) but the plastic work W^p is replaced by W^{pf} and the kinematic translation of the loading surface will not be considered here, i.e.

$$F(\epsilon_{ij}, \epsilon_{ij}^e, W^{pf}) = 0, \tag{40}$$

where W^{pf} is the plastic-fracturing work which is the total energy dissipation during loading and unloading [Fig. 7(b)].

Il'yushin's postulate requires that the work done in a deformation cycle, dW , be nonnegative. The dW is shown by a shaded area in Fig. 7(a). Denote $d\sigma_{ij}^{pf}$ as the sum of plastic stress increment, $d\sigma_{ij}^p$, and fracturing stress increment, $d\sigma_{ij}^f$, i.e.

$$d\sigma_{ij}^{pf} = d\sigma_{ij}^p + d\sigma_{ij}^f \tag{41}$$

then,

$$dW = \frac{1}{2} d\sigma_{ij}^{pf} d\epsilon_{ij} \geq 0, \tag{42}$$

and the normality rule (or flow rule) is represented as

$$d\sigma_{ij}^{pf} = d\lambda \frac{\partial F}{\partial \epsilon_{ij}}. \tag{43}$$

For a more general formulation, we may assume a nonassociated flow rule as

$$d\sigma_{ij}^{pf} = d\lambda \frac{\partial G}{\partial \epsilon_{ij}}. \tag{44}$$

Now the problem is reduced to the determination of the stress components: $d\sigma_{ij}^e$ and $d\sigma_{ij}^f$.

Observe that in Fig. 7(a) the fracturing component $d\sigma_{ij}^f$ depends on the rate of the stiffness degradation, i.e.

$$d\sigma_{ij}^f = -dC_{ijkl} \epsilon_{kl}^e. \tag{45}$$

In modeling the elastoplastic coupling behavior, Dafalias[2, 3] assumed that the elastic properties depend on the previous plastic deformations. Here we may further assume that the elastic stiffness tensor C_{ijkl} is a function of plastic-fracturing work W^{pf} ,

$$C_{ijkl} = C_{ijkl}(W^{pf}). \tag{46}$$

Then the rate of stiffness degradation can be expressed as

$$C'_{ijkl} = \frac{dC_{ijkl}}{dW^{pf}}. \tag{47}$$

By definition [see Fig. 7(b)], the energy dissipation dW^{pf} is represented by

$$dW^{pf} = \epsilon_{mn}^e (d\sigma_{mn}^p + \frac{1}{2} d\sigma_{mn}^f). \tag{48}$$

Then the stiffness degradation dC_{ijkl} is obtained as

$$dC_{ijkl} = C'_{ijkl} \epsilon_{mn}^e (d\sigma_{mn}^p + \frac{1}{2} d\sigma_{mn}^f). \tag{49}$$

Substitution of eqn (49) into (45) leads to

$$d\sigma_{ij}^f = -C'_{ijkl} \epsilon_{kl}^e \epsilon_{mn}^e (d\sigma_{mn}^p + \frac{1}{2} d\sigma_{mn}^f). \tag{50}$$

After some tensor manipulations of eqn (50), the relation between fracturing stress increment $d\sigma_{ij}^f$ and total inelastic stress increment $d\sigma_{ij}^{pf}$, can be obtained in the form

$$d\sigma_{ij}^f = T'_{ijkl} d\sigma_{kl}^{pf}, \tag{51}$$

where T'_{ijkl} can be viewed as a transformation tensor, and is expressed by

$$T'_{ijkl} = M_{ijmn} N_{mnkl}, \tag{52}$$

in which the tensor M_{ijmn} is the inverse of tensor \tilde{M}_{ijmn} and

$$\tilde{M}_{ijmn} = \frac{1}{2}(\delta_{im}\delta_{jn} + \delta_{in}\delta_{jm}) - \frac{1}{2}C'_{ijpq} \epsilon_{pq}^e \epsilon_{mn}^e \tag{53}$$

while N_{mnkl} is defined as

$$N_{mnkl} = -C'_{mnpq} \epsilon_{pq}^e \epsilon_{kl}^e. \tag{54}$$

As can be seen from eqn (41) that $d\sigma_{ij}^e$ is related to $d\sigma_{ij}^{pf}$ by the equation

$$d\sigma_{ij}^e = T^e_{ijkl} d\sigma_{kl}^{pf}, \tag{55}$$

where

$$T_{ijkl}^p = \frac{1}{2}(\delta_{ik}\delta_{jl} + \delta_{il}\delta_{jk}) - T_{ijkl}^f.$$

As soon as the relationships between the stress increments $d\sigma_{ij}^p$, $d\sigma_{ij}^f$ and $d\sigma_{ij}^{pf}$ have been established, the scalar $d\lambda$ in eqn (44) can be derived from the consistency condition in the usual manner. Here, as in eqn (20), $d\lambda$ has the same form as

$$d\lambda = \frac{1}{h} \frac{\partial F}{\partial \varepsilon_{ij}} d\varepsilon_{ij}, \quad (56)$$

but the scalar function h has the form

$$h = - \left[\frac{\partial F}{\partial \varepsilon_{ij}^p} D_{ijmn} T_{mnkl}^p \frac{\partial G}{\partial \varepsilon_{kl}} + \frac{\partial F}{\partial W^{pf}} \varepsilon_{mn}^e (T_{mnkl}^p + \frac{1}{2} T_{mnkl}^f) \frac{\partial G}{\partial \varepsilon_{kl}} \right].$$

Substituting eqn (56) into eqn (44), recalling that

$$d\sigma_{ij} = d\sigma_{ij}^e - d\sigma_{ij}^{pf},$$

and noting that

$$d\sigma_{ij}^e = C_{ijkl} d\varepsilon_{kl},$$

we obtain the constitutive equation for a plastic-fracturing solid

$$d\sigma_{ij} = \left[C_{ijkl} - \frac{1}{h} \frac{\partial G}{\partial \varepsilon_{ij}} \frac{\partial F}{\partial \varepsilon_{kl}} \right] d\varepsilon_{kl}, \quad (57)$$

which has the same form as that of eqn (22).

The general formulation given above is valid for the whole range of loading conditions (hardening or softening) suitable for modeling the stress-strain behavior of materials with elastoplastic coupling.

5. EXAMPLE IMPLEMENTATION TO CONCRETE MATERIALS

Although the strain-space formulation provides a theoretically consistent form suitable for material modeling in both hardening and softening ranges, it is still not a simple matter to apply it in engineering applications. The present main difficulties are to define properly the scalar functions for an actual material such as concrete. These include: (1) the loading function F in strain-space, (2) the plastic potential function G in strain-space, and (3) the stiffness degradation rate C_{ijkl}^e . There is very little good and comprehensive experimental data for materials like concrete in the softening range. In order to apply the theory to concrete, for example, some restriction and further assumptions have to be made. The application of the present theory to concrete materials is described below.

At present we will restrict our attention to model the softening behavior of a concrete element failed in a mixed (cracking and crushing) mode. In the mixed mode of failure, the element is subjected to a compressive loading with its maximum principal stress nonpositive, so that no major cracks will be developed in the concrete element. Further, to avoid the failure mode due to crushing, its maximum principal strain at failure is assumed always positive. Details of this can be found elsewhere (Hsieh *et al.*[16]).

As for the definition of loading surface in strain-space, Bazant and Kim proposed a loading function that has the same form as that of Drucker-Prager loading surface in stress-space, while Dougill[17] assumed a linear function of strain components that represents a

single hyperplane in deformation space :

$$F = \lambda_{ij}\epsilon_{ij} - k(W) = 0, \tag{58}$$

where the coefficients λ_{ij} are constants, and k is a positive scalar function of the energy dissipation W .

According to the experimental observations, a prominent feature of post-failure behavior of concrete is a relatively rapid dilation of the overall volume. Such a dilation is due mainly to the voids within the body of the material which are caused by a fracture propagation process. Based on this observation, the volume dilation may be used as a loading criterion in the post-failure range. Here we propose a simple loading function in strain-space in the form

$$F = \epsilon_{ij}\delta_{ij} - k(W^{pf}) = 0, \tag{59}$$

Equation (59) is a special case of eqn (58). It represents a plane perpendicular to the hydrostatic axis $\epsilon_{11} = \epsilon_{22} = \epsilon_{33}$ in strain-space. k is a function of plastic and fracture energy dissipation W^{pf} , representing the current volumetric strain of the material.

Loading condition related to the loading surface (59) implies that if a concrete element is confined such that no volume dilation occurred, then there will be no stress relaxation either; even the element may proceed to deform distortedly. In fact, the choice of a loading surface with either Drucker–Prager’s form, or a linear form as eqn (58), or simply the form of eqn (59), requires more experimental evidence.

As for the parameter representing the elastoplastic coupling, a general formulation has been given previously and the key parameter is the stiffness degradation rate tensor C'_{ijkl} . This quantity could be obtained from experimental measurements. Herein, for simplicity, we shall assume the elastic response of the material remains isotropic. Thus the elastic tensor C_{ijkl} has two independent constants (E and ν), as does the degradation rate tensor C'_{ijkl} . The rate of Young’s modulus E' , and Poisson’s ratio ν' could be obtained by a strain-controlled uniaxial compression test.

As for the choice of a proper plastic potential function G , we note that the normality rule associated with the loading surface eqn (59) leads to only the hydrostatic tension stress components in the plastic-fracturing stress $d\sigma^{pf}$ (Fig. 7). Since the plastic-fracturing stress $d\sigma^{pf}$ can be considered as the relaxed stress tensor during softening and the incremental volume dilation under compressive loading condition is caused mainly by shear or deviatoric stress components, it follows that strain-softening behavior of concrete should be accompanied by hydrostatic as well as deviatoric stresses relaxed. In view of this, a non-associated flow rule is used in this development. The plastic potential function G is assumed to have the form

$$G = \alpha I_1 + \sqrt{J_2} - k' = 0, \tag{60}$$

where I_1 is the first invariant of strain tensor, J_2 is the second invariant of strain deviatoric tensor and α and k' are constants.

In summary, three assumptions are made in the following development : (i) the volumetric strain is used to define the loading surface, (ii) elastic behavior is isotropic, and (iii) plastic potential function is of Drucker–Prager type.

From the loading function given in eqn (59), we have

$$\frac{\partial F}{\partial \epsilon_{ij}} = \delta_{ij}; \quad \frac{\partial F}{\partial \epsilon_{ij}^2} = 0; \quad \frac{\partial F}{\partial W^{pf}} = - \frac{dk}{dW^{pf}}. \tag{61}$$

Substituting eqn (61) into eqns (56) and (57), leads to

$$d\sigma_{ij} = \left[C_{ijkl} - \frac{dW^{pf}}{dk} \frac{(\partial G / \partial \epsilon_{ij}) \delta_{kl}}{\epsilon'_{mn} [T'_{mnpq} + \frac{1}{2} T'_{mnpq}] (\partial G / \partial \epsilon_{pq})} \right] d\epsilon_{kl}, \tag{62}$$

where

$$\frac{\partial G}{\partial \epsilon_{ij}} = \alpha \delta_{ij} + \frac{s'_{ij}}{2\sqrt{J'_2}}, \tag{63}$$

and s'_{ij} is the strain deviatoric tensor.

The transformation tensors T^p_{mnl} and T^f_{mnl} defined in Section 4 can be calculated if the stiffness degradation rate C'_{ijkl} is known. Assuming elastic isotropy, we can express C'_{ijkl} in the form

$$[C'] = \begin{bmatrix} C_1 & C_2 & C_2 & & 0 \\ C_2 & C_1 & C_2 & & \\ C_2 & C_2 & C_1 & & \\ & & & C_3 & \\ & & & & C_3 \\ 0 & & & & & C_3 \end{bmatrix}, \tag{64}$$

where

$$C_1 = \frac{E'(1-\nu)}{(1+\nu)(1-2\nu)} + E\nu' \frac{2\nu(2-\nu)}{(1+\nu)^2(1-2\nu)^2},$$

$$C_2 = \frac{E\nu}{(1+\nu)(1-2\nu)} + E\nu' \frac{1+2\nu^2}{(1+\nu)^2(1-2\nu)^2},$$

$$C_3 = \frac{E'}{2(1+\nu)} - \frac{E\nu'}{2(1+\nu)^2},$$

in which E and ν are the current values of Young's modulus and Poisson's ratio, respectively, E' is the degradation rate of Young's modulus and ν' is the rate of Poisson's ratio.

With C'_{ijkl} known, elastic stiffness matrix C_{ijkl} in eqn (62) can be updated in each loading step.

In order to predict softening behavior for a specific material, the material characteristics must be given, including the rate of energy dissipation, dW^p/dk , and the rate of elastic constants E', ν' . Spooner and Dougill[18] performed an experimental study on the behavior of concrete in uniaxial compression and attempted to define a quantitative measurement of damage in concrete. They reported that the energy dissipation due to microcracking and stiffness degradation can be expressed as a function of strain as shown in Fig. 8(a). Based

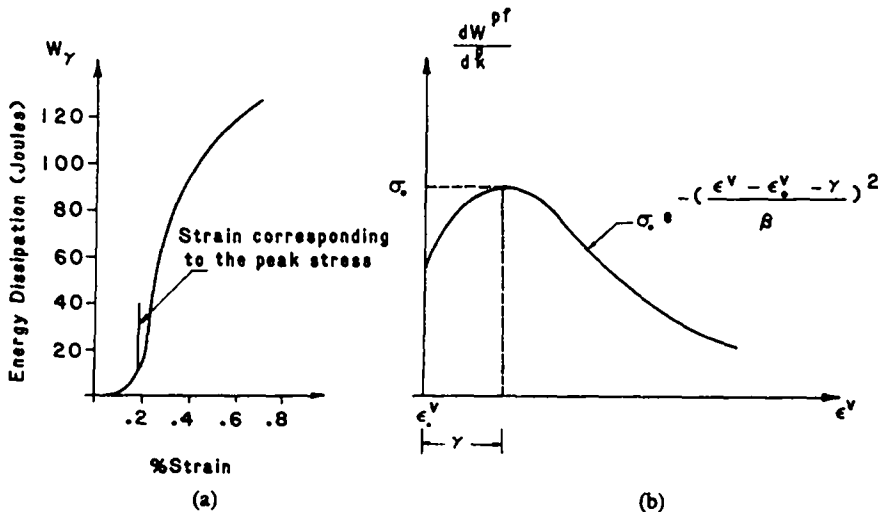

Fig. 8. (a) Energy dissipated in uniaxial compression[18]. (b) Energy dissipation rate as function of ϵ^v .

on this experiment, the energy dissipation rate dW^p/dk may be shown in Fig. 8(b) and expressed as a function of volumetric strain,

$$\frac{dW^p}{dk} = \sigma_0 e^{-((\epsilon' - \epsilon'_0 - \gamma)/\beta)^2} \tag{65}$$

where σ_0 is the maximum energy dissipation rate, ϵ^p is the volumetric strain, ϵ'_0 is the volumetric strain corresponding to peak stress, and γ, β are constants.

As for the rate of elastic constants, E', ν' , no experimental data are available. Dafalias[2] reported a theoretical study that started from the second law of thermodynamics and the consistency condition in strain-space, derived two inequalities which served as guidelines for the selection of the degradation rate of the two constants E' and ν' . However, the normality rule and von Mises or Tresca types of loading conditions had been used in his derivation, so that the results cannot be used here directly. Nevertheless, experiments do show that Young's modulus E decreases while Poisson's ratio ν increases during strain-softening. Therefore E' and ν' are taken as negative and positive values, respectively.

The above formulation has been coded in the material subroutine. Some of the model predictions are given in Figs. 9 and 10. A reasonable trend of the predicted softening stress-strain curves can be observed.

6. SUMMARY AND REMARKS

General forms of strain-space plasticity formulations applied to strain-hardening-softening material with or without elastoplastic coupling have been developed. The use of strain-space plasticity overcomes the difficulties encountered in the application of stress-space plasticity to strain-softening modeling.

The impetus of this study is to find a method to model the post-failure behavior of concrete materials, because concrete failed in a mixed mode that could soften in a multiaxial form associated with elastoplastic coupling. In these cases the microcracks or fractures are generally not strongly directionally oriented but may distribute randomly, and cause a multiaxial loss in strength and stiffness. The strain-space plasticity theory provides a rational tool in modeling the softening behavior. However, difficulties arise in the application of the theory to an actual material such as concrete, because a realistic loading surface in strain-space is hard to define due to lack of experimental data.

As an attempt, the loading surface proposed herein is simply the volumetric strain

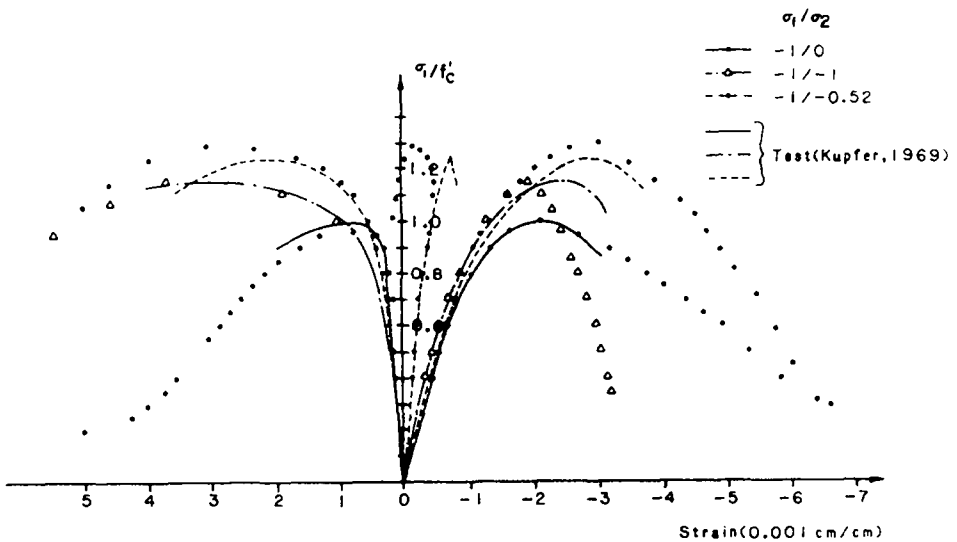

Fig. 9. Predicted softening stress-strain curve (using Kupfer's data[19]).

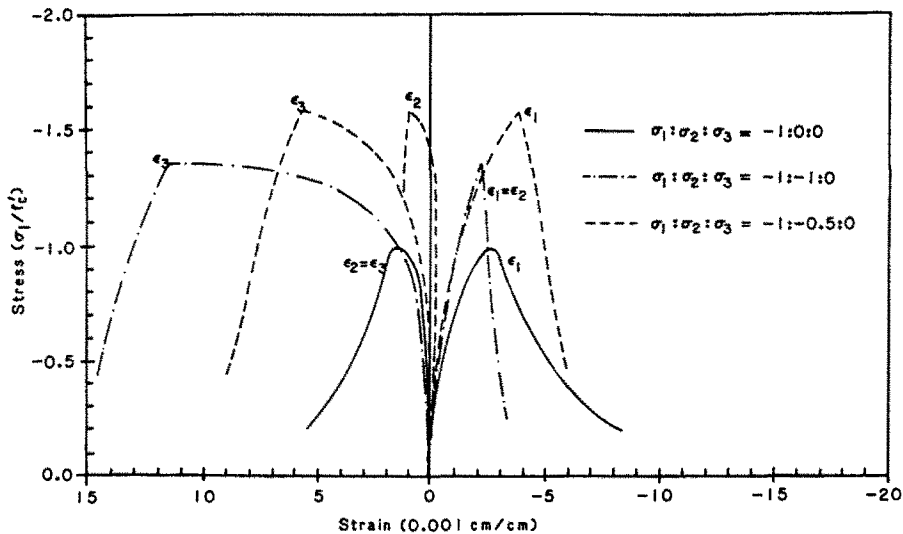

Fig. 10. Predicted softening stress-strain curve (using AFWL data[20]).

because concretes do exhibit volume dilation behavior during failure. This model works reasonably well in biaxial and triaxial compressive loadings with a relatively low hydrostatic compressive stress. However, in high hydrostatic compressive stress region, which may result in crushing failure, this loading criterion may not be adequate. As more and more experimental data regarding softening behavior of concrete will be available in the future, it is possible to find a more rational shape of the loading surface in strain-space and to describe its evolution more clearly during strain-softening.

Acknowledgements—The work reported in this paper was supported by the National Science Foundation under Grant No. CEE-8209626 to Purdue University.

REFERENCES

1. B. P. Sinha, K. H. Gerstle and L. G. Tulin, Stress-strain relations for concrete under cyclic loading. *ACI J.* **61**, 195–211 (1964).
2. Y. F. Dafalias, Elasto-plastic coupling within a thermodynamic strain space formulation of plasticity. *Int. J. Non-Linear Mech.* **12**, 327–337 (1977).
3. Y. F. Dafalias, Il'yushin's postulate and resulting thermodynamic conditions on elasto-plastic coupling. *Int. J. Solids Struct.* **13**, 239–251 (1977).
4. P. M. Naghdi and J. A. Trapp, The significance of formulating plasticity theory with reference to loading surface in strain space. *Int. J. Engng Sci.* **13**, 785–797 (1975).
5. P. J. Yoder and W. D. Iwan, On the formulation of strain-space plasticity with multiple loading surfaces. *J. Appl. Mech.* **48**, 773–778 (1981).
6. J. Casey and P. M. Naghdi, On the nonequivalence of the stress-space and strain-space formulations of plasticity theory. *J. Appl. Mech.* **50**, 350–354 (1983).
7. J. W. Dougill, Some remarks on path independence in the small in plasticity. *Q. Appl. Math.* **32**, 233–243 (1975).
8. J. W. Dougill, On stable progressively fracturing solids. *Z. Angew. Math. Phys.* **27**, Fasc. 4, 423–437 (1976).
9. Z. P. Bazant and S. S. Kim, Plastic-fracturing theory for concrete. *J. Engng Mech. ASCE* **105**, 407–428 (1979), with errata in 106.
10. W. F. Chen, *Plasticity in Reinforced Concrete*. McGraw-Hill, New York (1982).
11. D. J. Han and W. F. Chen, On constitutive modeling of concrete materials. Proceedings of the RILEM-CEB International Conference on Concrete under Multiaxial Conditions, Toulouse, France, May 22–24, Vol. 1, pp. 210–219 (1984).
12. D. J. Han, Constitutive modeling in analysis of concrete structures. Ph.D. Thesis, School of Civil Engineering, Purdue University, West Lafayette, IN, May, 1984 (unpublished).
13. Y. F. Dafalis and E. P. Popov, Plastic internal variables formalism of cyclic plasticity. *J. Appl. Mech. ASME* **98**, 645–651 (1976).
14. A. A. Il'yushin, On the postulate of plasticity. *Prikl. Mat. Mekh.* **25**, 503–507 (1961).
15. A. C. Palmer, G. Maier and D. C. Drucker, Nonlinear relations and convexity of yield surfaces for unstable materials or structural elements. *J. Appl. Mech.* **34** (Transaction ASME 89, Series E), 464–470 (1967).
16. S. S. Hsieh, E. C. Ting and W. F. Chen, A plastic-fracture model for concrete. *Int. J. Solids Struct.* **18**, 181–197 (1982).

17. J. W. Dougill, J. C. Lau and N. J. Burt, Towards a theoretical model for progressive failure and softening in rock, concrete and similar materials. In *Mechanics in Engineering* (Edited by R. N. Dubey and N. C. Lind), pp. 335-355. University of Waterloo Press (1977).
18. D. C. Spooner and J. W. Dougill, A quantitative assessment of damage sustained in concrete during compressive loading. *Mag. Concrete Res.* **27**, 151-160 (1975).
19. H. Kupfer, H. K. Hilsdoff and H. Rüsç, Behavior of concrete under biaxial stresses. *ACI J.* **66**, 656-666 (1969).
20. S. J. Green and S. R. Swanson *et al.*, Static constitutive relations for concrete, AFWL-TR-72-244, Air Force Weapons Laboratory, Kirtland Air Force Base, New Mexico (1973).